

portable

flue gas

monitoring



LAND

Combustion & Environmental Monitoring

An **AMETEK**® Company

LANCOM III

the world's most versatile portable flue gas analyzer



The new Lancom III is now firmly established at the forefront of portable flue gas analyzer technology.

In excess of two thousand Lancom analyzers are in use today, in a wide range of applications - all subjected to very different measurement conditions.

Features & Benefits

- Monitoring of up to 17 measurement parameters - *one instrument to meet all requirements*
- Up to 9 simultaneous gas measurements - *user selectable*
- Weighs only 6kg (13lbs) - *easily carried around plant*
- Robust, industrial design - *for daily use in the harshest plant environments*
- Integral printer - *instant record of measurement readings*
- Wake and Sleep, semi-continuous operation mode - *for periodic unattended operation*
- Range of user selectable options - *ideally matched to application requirements*
- Data acquisition & analysis software - *capture, manipulate, and report data on your PC*
- Simple field upgrade - *add features and options as and when required*
- Meets US EPA CTM 034 reference method - *report generation to recognized standards*

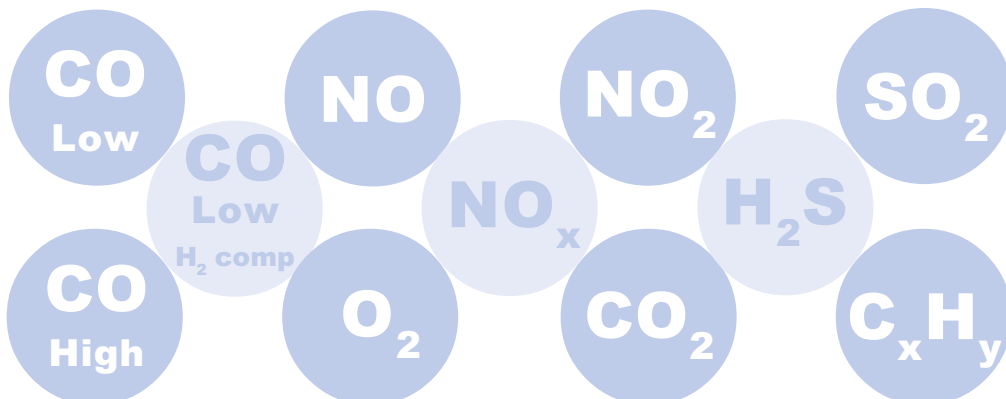

Measurement Specifications

Sensor	Standard Range	Max. Range [#]	Accuracy	Resolution
Oxygen, O ₂	0 to 25.0 % Vol.	0 to 30.0 % Vol.	±1 %	±0.1 % Vol.
Carbon Monoxide, CO (low)	0 to 2 000 ppm	0 to 10 000 ppm	±2 %*	±1 ppm
CO (H ₂) compensated	0 to 2 000 ppm	0 to 4 000 ppm	±2 %*	±1 ppm
Carbon Monoxide, CO (high)	0 to 4 %	0 to 10 %	±2 %*	±1 ppm
Sulphur Dioxide, SO ₂	0 to 2 000 ppm	0 to 5 000 ppm	±2 %*	±1 ppm
Nitric Oxide, NO	0 to 1 000 ppm	0 to 5 000 ppm	±2 %*	±1 ppm
Nitrogen Dioxide, NO ₂	0 to 100 ppm	0 to 1000 ppm	±2 %*	±1 ppm
Hydrogen Sulphide, H ₂ S	0 to 200 ppm	0 to 1 000 ppm	±2 %*	±1 ppm
Carbon Dioxide, CO ₂ **	0 to 25.0 % Vol.	-	±0.5 % Vol	±0.1 % Vol.
Hydrocarbons	0 to 5.0 % Vol. (Application dependent)			
Flue Gas/Ambient Temperature	Measured			
Draft	± 51 cm / 20 " Water Gauge ***			
Flow (velocity)	1 to 50 m/s			
<i>Note: Special ranges are available</i>				
<i>*Calibration per CTM034 or LAND factory procedure</i>				
<i>**True measurement if sensor fitted (calculated if not)</i>				
<i>***Reduced to ± 26 cm / 10 " Water Gauge when used with flow probe</i>				
<i># Operating at maximum possible range may affect sensor life and accuracy</i>				



Combustion & Environmental calculations

- Combustion efficiency
- Excess Air
- Oxygen normalization
- Wet or dry basis
- Loss
- CO (where no sensor fitted)
- Total NO_x
- Automatic conversions - ppm, mg/m³, lb/mmBtu, ng/J

Sensor Types

Lancom analyzers use the following sensors in order to measure gas concentration levels.

Sensor Type	Gas
Electrochemical	CO Low, CO High, CO Low H ₂ compensated, O ₂ , NO, NO ₂ , SO ₂ and H ₂ S
Infrared	CO ₂
Pellistor/Catalytic	C _x H _y

Convenient catchpot - visible and accessible

The side-mounted catchpot is both fully protected and highly visible for rapid checking, removal and emptying.



Instant record of measurement data

The built-in thermal printer provides an immediate record of the measurement data. All essential information including date and time are printed.

```

LONFIELD POWER STATION
BOILER NO 2
MAIN SITE
-----
Type of fuel:
Light Fuel Oil
Dry analysis
O2 normalisation: off
-----
Date: 05.08.02
Time: 10:23
-----
T ambient   :      25   C
T gas       :      266   C
Tg - Ta     :      241   C
-----
CO          :      2055  ppm  55mg/Nm3
SO2       :      105   ppm
NO2      :      43    ppm
NO         :      272   ppm
O2       :      1.71  %
CxHx       :      0.65  %
H2S      :      742   ppm
CO2     :      14.3  %
NOx     :      315   ppm
-----
Velocity    :      3.0  m/s
Flue Temp. :      266   C
Flow       :      36   cu.m/hr
-----
efficiency  :      90.2  %
loss       :      9.8   %
excess air  :      10.8  %
water      :      0.0   %
O2 norm  :      0.0   %
-----
SAMPLE POINT E34B
    
```

Flue gas & ambient temperature

The analyzer takes a direct thermocouple temperature measurement of the flue gas, and has an ambient temperature sensor fitted.

These are required for making accurate combustion efficiency calculations.



Easy access sensors

Each sensor is installed in its own unique position. Replacing a sensor is a simple process and will take only a few minutes. Undo the side panel for access, swap the sensor and re-calibrate.

leading the way

Direct CO₂ Measurement capability

New micro-sensor technology used in the Lancom III, enables direct measurement of CO₂ in flue gas.

The combination of this revolutionary CO₂ sensor with the measurement capability offered by the flow probe, can give quantitative information on greenhouse gas emission.

Backlit LCD user interface

The analyzer is fitted with a full function, sealed alpha-numeric backlit LCD and user interface.

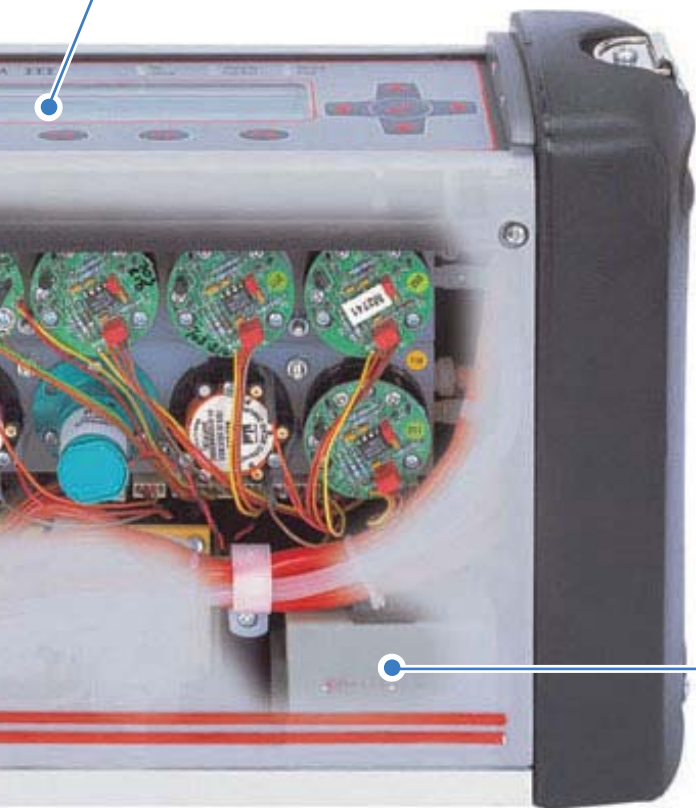

Straightforward servicing

Service is simple via the menu driven software.

Self diagnostic checks are run continuously on sensor life and calibration status together with battery life.

Clip-in filters - visible and quick to change

The chemical and particulate filters are mounted on the side of the instrument. Visible inspection and replacement is straightforward. The rugged case design protects all components from damage.



Long life rechargeable battery

Rechargeable batteries give up to 8 hours continuous operation. A power supply cable is supplied for mains power operation and battery recharging.

Automatic Sensor Protection

Auto Purge of sensors on system shutdown

Clears system of corrosive flue gases.

CO overrange protection

Automatically purges low CO sensor and switches to high range measuring mode, if high levels of CO are encountered.

Setup and measure within minutes

Simply switch on, an automatic zero calibration is performed by the analyzer. Plug in the sample probe and take real-time gas readings in a matter of minutes.

in portable flue gas monitoring

Selecting the analyzer

The following features are standard on all instruments:

- Standard Sample Probe
- Built-in Thermal Printer
- Data Logging
- RS 232 or RS 422 Serial Communications Interface
- Carrying Case

The user selects which gases (between 3 and 9) and options are required.



Options & Accessories

- Draft Measurement - *internal stack pressure in hPa or inches water gauge*
- Flow Measurement - *flue gas velocity, flow rate and mass emissions rate*
- Smoke Measurement - *readings to Bacharach smoke scales*
- Range of Sample Probes - *Smoke, Flow, DrySampler* and High Temperature*
- Insight Data Acquisition Software system - *simple-to-use Windows™ reporting software*
- Analogue outputs (12 current loops, independently user configurable)
- Wake and Sleep facility (Semi-continuous monitoring) - *cyclical measurement*
- Dual language display options - *English, French, German, Italian, Spanish & Polish*

*US Patent No. 6782767

Sample Probes



A wide range of sample probes suitable for specific application and measurement requirements are available.

Request Information ref. PDS 198

Wake and Sleep

Semi-continuous monitoring can be achieved by cyclically sampling and logging gas concentrations over a period of time. This is achieved by alternate 'wake' and 'sleep' phases. User settings include wakeup interval, number of samples between wakeup, sample interval and first wakeup.

Insight - Data Acquisition & Analysis Software

Insight is a Windows™ based data acquisition software program, used for logging measurement data directly from a Lancom portable analyzer.

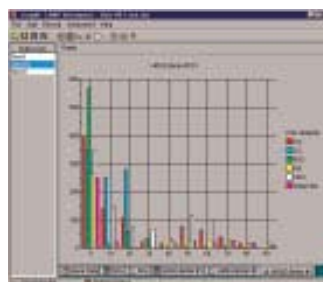

Data can be analyzed either in real time or during review of stored data.

A range of statistical and graphical tools, allow the user to perform measurements, manipulate data, present and print data.

Request Information ref. PDS 205

How the analyzer works ?

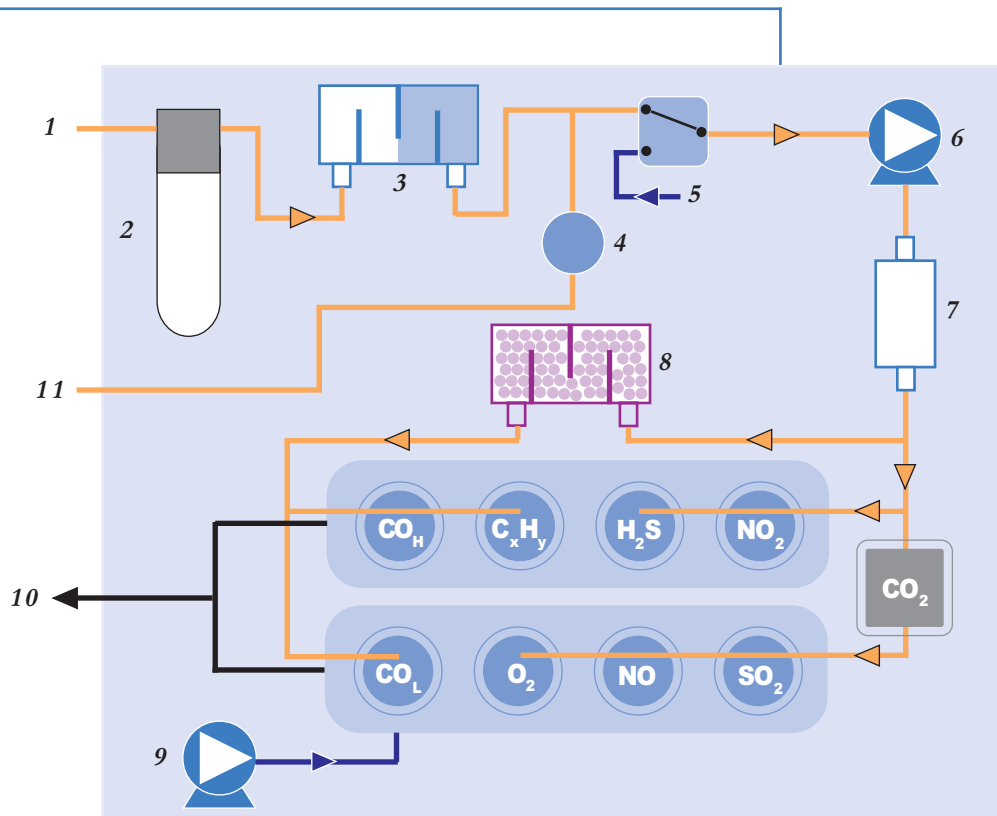

Key

1. Sample Gas Inlet
2. Water Catchpot
3. Particulate Filter
4. Pressure Sensor
5. Air Input
6. Sample Pump
7. Expansion Chamber
8. Chemical Filter
9. Purge Pump
10. Exhaust
11. Flow Probe Inlet

Integral sample conditioning

The gas sample is drawn into the analyser via a sample probe and hose connected to the input connection on the front panel of the analyser. The sample enters the water catchpot where residual water is removed. The sample gas is then passed through a 0.1 micron particulate filter.

Filtering out damaging chemicals - prolonging sensor life

After removing flow and pressure variations in the sample flow, the gas is routed to the sensor manifolds. To ensure that the CO and C_xH_y sensors are not poisoned by other gases in the sample, it is fed through a chemical filter prior to being routed to these sensors. This action ensures longer sensor life and higher accuracy.

Sensor protection

To protect the CO_{Low} sensor from high levels of CO (normally levels >2000ppm), a dedicated purge pump is automatically triggered which blows ambient air to protect the sensor ensuring optimum recovery time and maximum sensor life.

Sensor accuracy and longevity

To maintain sensor integrity, they are purged with fresh air each time the analyzer is switched on or off. For accuracy they are calibrated on 'switch on' with ambient air.



View showing measurement sensors

Further Information

Supplied & serviced by :

**Q Instrument Services
Limited, Cork.**

Phone : 086-8129925

Fax : 021-4341218

Email : info@qlimited.com

www.qlimited.com

Specifications

Display	Full function alphanumeric/graphic LCD with backlight 40 x 8 Matrix Liquid Crystal
Keypad	Tactile membrane (integral with display) functions keys and cursors
Indicators	LED type for ON (Power), Stand-by, Service, Charge, Low Batt., Fault
Power Supply	95-265 V a.c. $\pm 10\%$, 50-60 Hz, 30 Watts Rechargeable battery 2 x 6 V 4 Amp. hours Typical 8 hr. operation, dependent on options fitted
Ambient Temperature	-5 °C to 45 °C (+23 °F to 113 °F)
Case	Medium density blended polyethylene
Dimensions	453 x 120 x 245 mm (17.8" x 4.7" x 9.6 inches)
Weight	6 kg (13 lb)
Standard Accessories	Integral water catchpot and filters Rechargeable lead acid battery (internal) Mains power supply cable Probe handle, Hose and Probe pipe (Lengths listed below under options) Carrying case Thermal printer Data logging

Options

Min of 3 to max 9 gases in total, from a selection of 9 gases
 Probe length options - 0.3, 1.0, 1.5, 2.0, 3.0m/1, 3.3, 5, 6.5, 10ft
 Alternative probes available - *Refer to Data Sheet Reference PDS198 for details*
 Hose length options - 3 m/10 ft or 10 m/33 ft
 Draught Measurement
 Flow Measurement, probe length options - 0.7, 1.2, 2.2, 3.0 m/2.3, 3.9, 7.2, 9.8 ft
 Smoke Measurement, probe length options - 0.3, 0.75, 1.0 m/1, 2.4, 3.2 ft
 Insight Data Acquisition Software system - *Refer to Data Sheet Reference PDS205 for details*
 Analogue outputs (12 current loops, independently configurable)
 Wake and Sleep facility (Semi-continuous monitoring)
 Language display options

Continuous Product Development may make it necessary to change these details without notice

Copyright © 2003 - 2005 Land Instruments International



PDS 198 - LANCOM
Sample Probes



PDS 205 - Insight Data
Acquisition Software

LAND has a comprehensive range of Combustion and Environmental Monitoring Instrumentation.

LAND

www.landinst.com

An **AMETEK** Company



Approval applies to products designed and manufactured in the UK



Approval applies in the USA



Utilizes ETV Verified Technology (Report Sept. 2000)

PDS206/08/06